

TS501			

HG) \$%

J' "\$



L] UaYb Hcd! =ch HVMbc` c[m 7c" ž @hX"

&\$%! \$&! %\$	J% \$		
&\$%! \$)! %	J% %		
&\$%! \$'! %%	J% &		
&\$&\$" %%' &	J' " \$		



% %

HG) \$%

' &

HG) \$%

FH

& # ' ; # (;

FG& & FG(,) HH@





· 6#H %* +\$*! % - *
, & &\$\$, Ac g

<>#H +)! &\$ \$+

<>#H +*! &\$ \$+

<>)&! &\$ \$-

<>)&! &\$ \$-

G-155A

ž

&"); #"; #(;

b

)

*

+

%*A6

%\$

,

N] [6YY

-

%\$

%' '

%' "%

	9, GA- \$\$#, GA% \$\$A<n ; GA,) \$#- \$\$#% \$\$#% \$\$A<n ; GA d\UgY &#&Z ; DFG W Ugg %\$ W Ugg %&
	,) " *?Vdg
	; GA,) \$#- \$\$ O ' X6a ; GA% \$\$#% \$\$ O \$X6a
	O! %\$+X6a

%' "% &

7DI	' &
: @5G<) %&?6
GF5A	&) *?6
: ^ Ug\	%*A6

%' "'

& FG& & f% î XYVi [ȷ % FG(,) * fl fl

	%\$r' \$(\$Vdg
	DKF GM6 CB@-B9 9FFCF
	GA5)\$
G=A#l =A	%, J#' J G=A#l =A %?J 9G8
	#
	' (%* 58 (! &\$a5 \$!)J
	& (
	\$ \$!' J87
	%)!' \$J87
	% %&J %5
	& ' \$J87#&&\$J57
)5
	%&\$K
	& &J
	& C7

% ' " (

	87 %&J#%")5
	87)r' *J
	(\$a5 ()a54%&J87
	(\$a5 *\$a54%&J87

% ' ")

	=D \$
	%%\$y %%\$y &' aa fl y y t
	' &\$[

% ' " *

	!)rZ+) 7
	!(\$rZ,) 7
	-)i fl t

&" %

&" &

&" &" %

◇ % fl 匕

◇ fIGA5 匕 %

◇ %&J87#%) 5 %

◇ FG&' & %

◇ %& D=B % %\$ D=B %

◇

◇

&" '

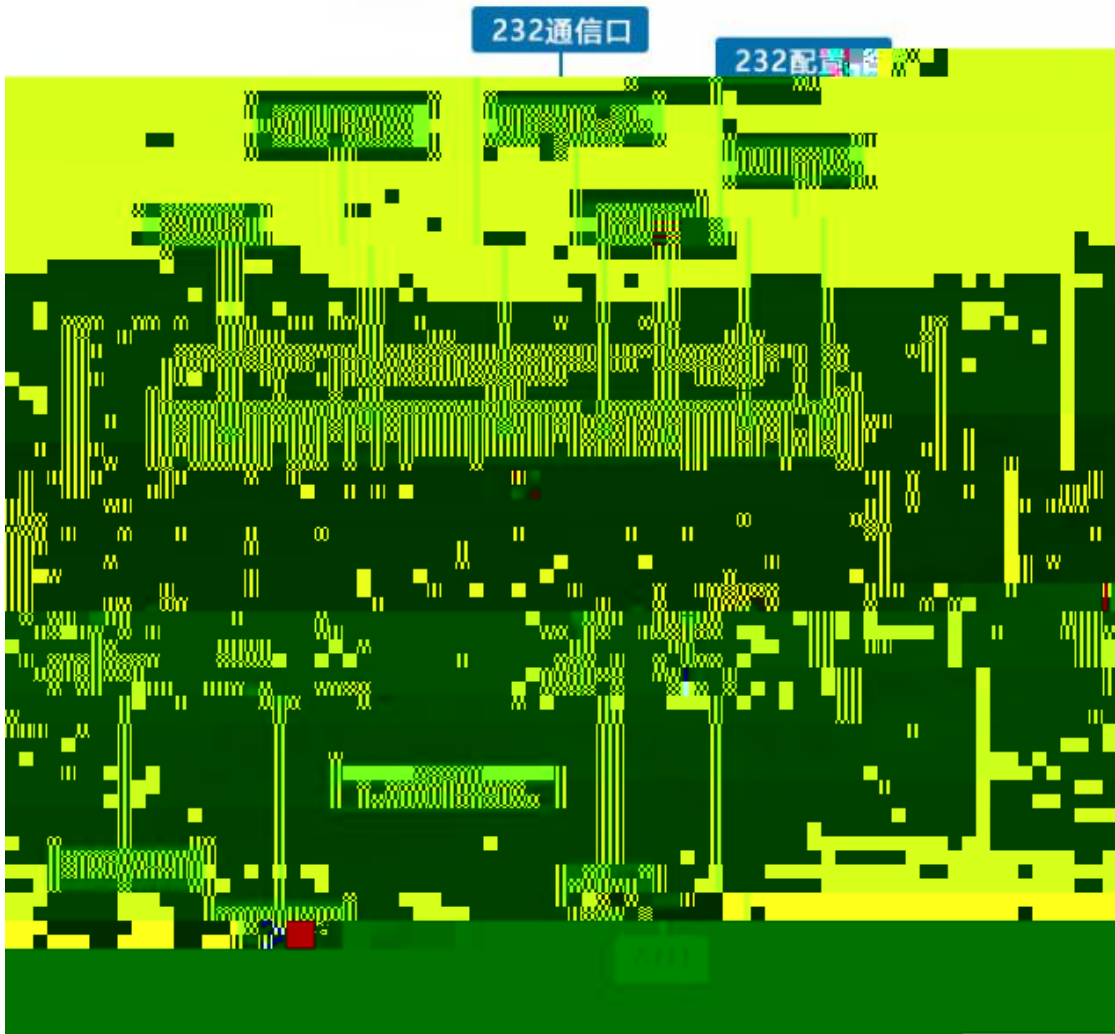

%	J=BZ		
&	J=Bl		
'	; BB	& & XYVi [
(FL8\$	& & XYVi [FL	
)	HL8\$	& & XYVi [HL	
*	5\$	(,) 5	
+	6\$	(,) 6	
,	8=\$	\$	5%
-	8=%	%	6%
;%	; BB	& &	



FG& &

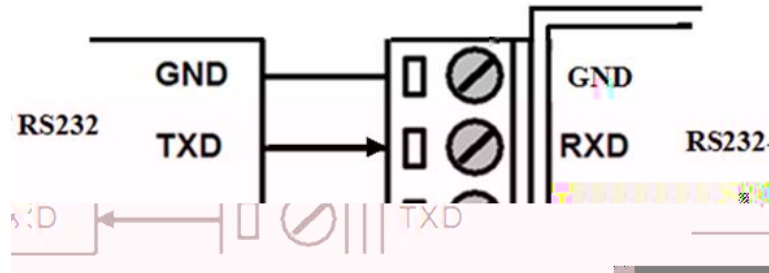

FG(,)

FG(,)

- *\$\$ Vdg

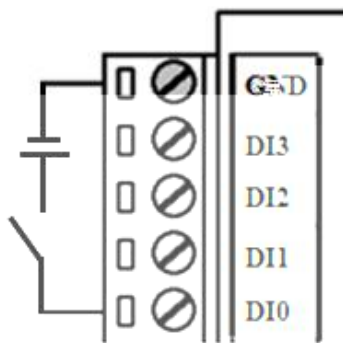
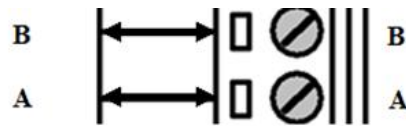

' \$J87

%5

' \$K

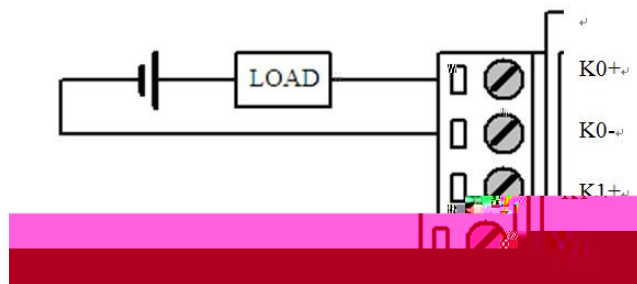

(! &\$a5

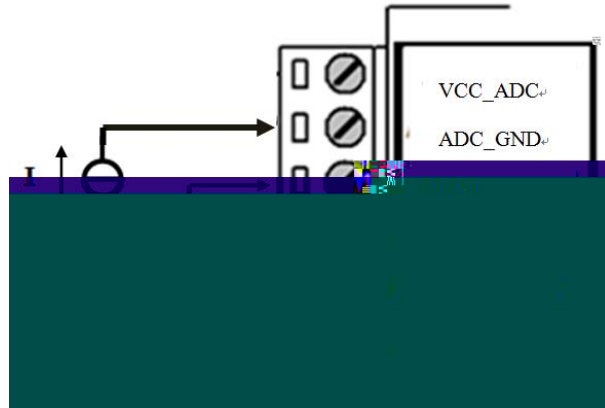

(! &\$a5

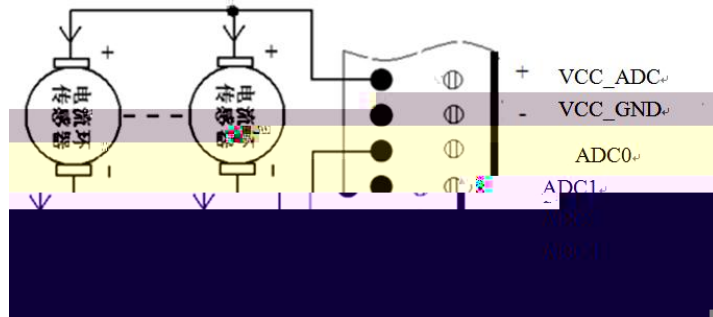

&")

%&J87#%) 5

)r' *J

' \$\$aJ

' *J

(K

%&J87#%) 5

&" *

DKF		
GMG		
Cb']bY		
9ffcfcf		

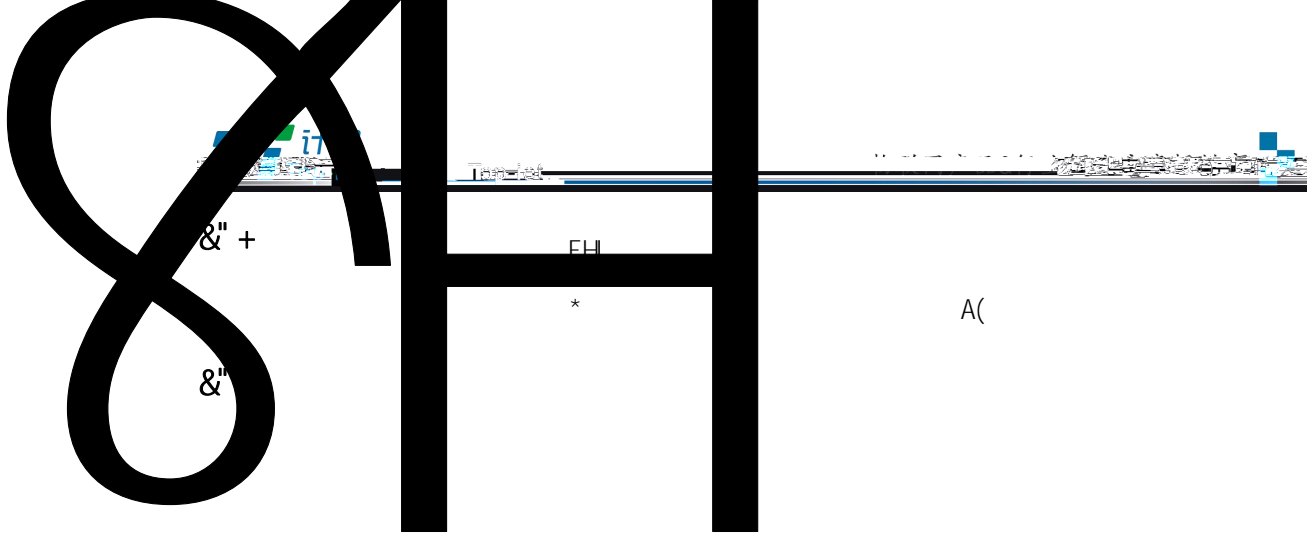

FH

HG) \$% FH

FG& & FG(,)

FH



)

FH

' "%

FH

FH

Amge'!) " * " %

' " (

FH

' ")

FH

("%

("&

FH

FG(,)

(!&\$a5

("'

%

%

%

" (

FH

FH

D7

FG& &

FH

91 W`

D7

")

FH

FG & &

FH

FG&' & % D7

D7

FH

FH

FH

G=A

FH

)" %

)" % %

FG& &

FH

FH

)" % &

FH

)" % '

G=A

)" &

7CA% %& &\$\$

""

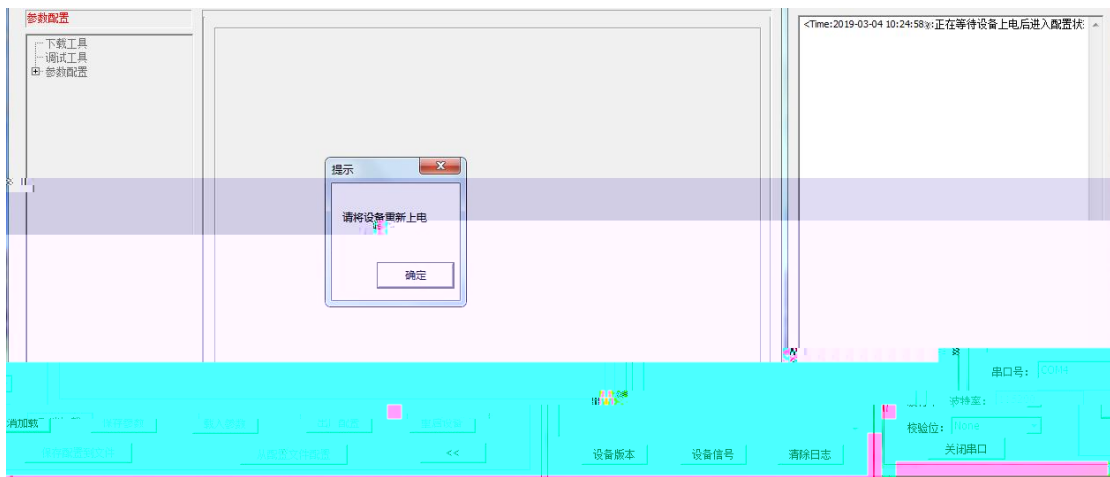

)" &% FH7

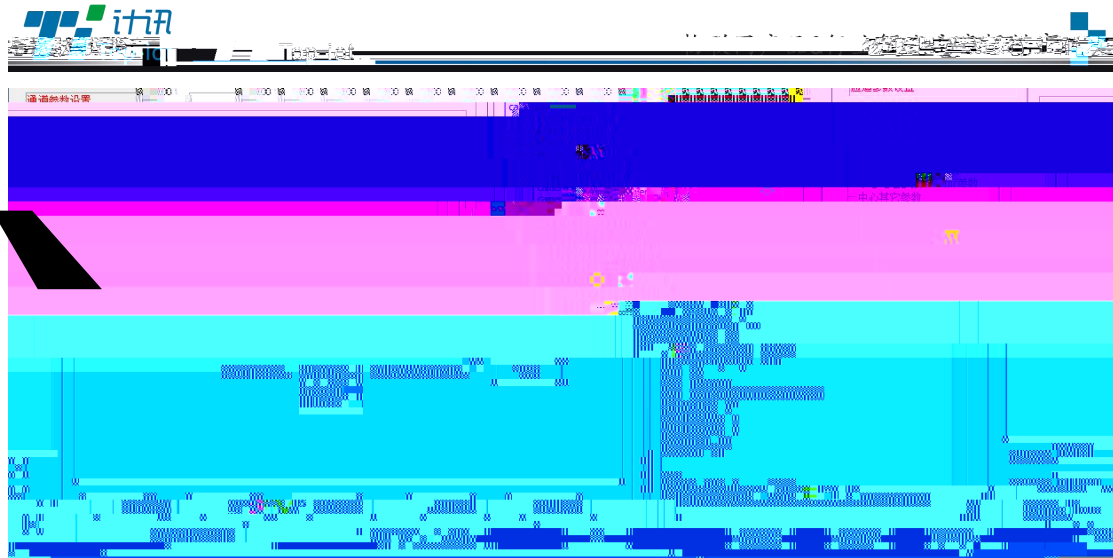

FH7

HG) \$%

FH7

)" &" &

HG) \$%

H
C200

L

\$

Ä

587	HG) \$%	'	(
8=	HG) \$%	&	(
	HG) \$%		
8C	HG) \$%	&	

)" &"'

HG) \$% FG&' & FG(,.)

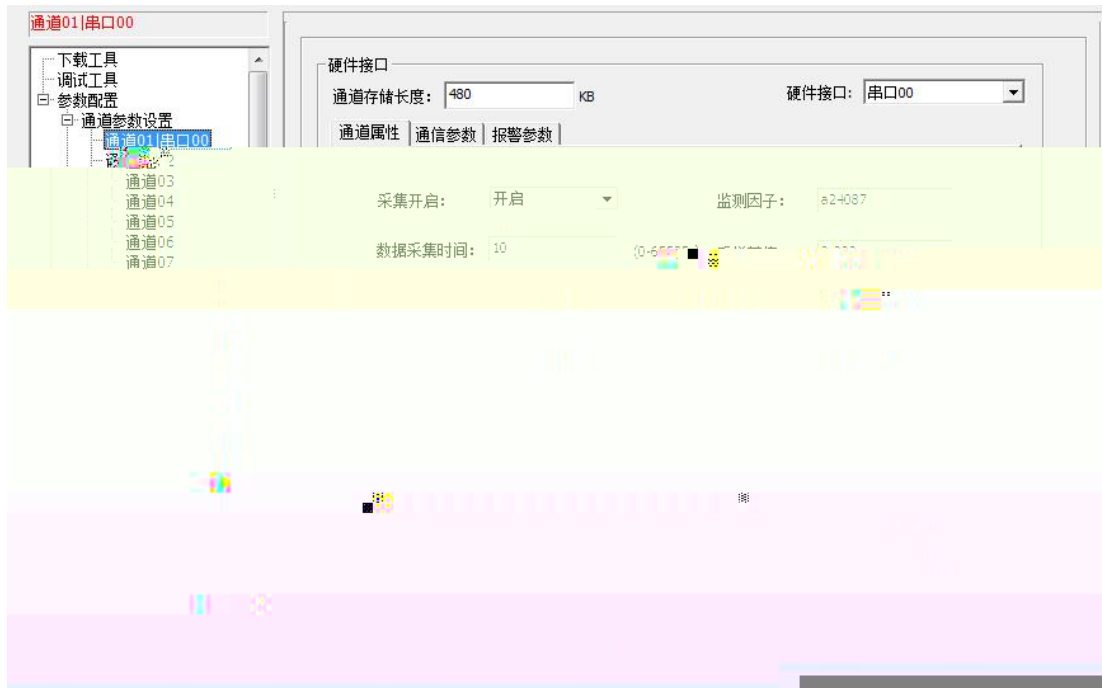

	HG) \$% \$! *)')')g
	FH
	%' \$\$
	%' \$\$
	VaPaP a' #g

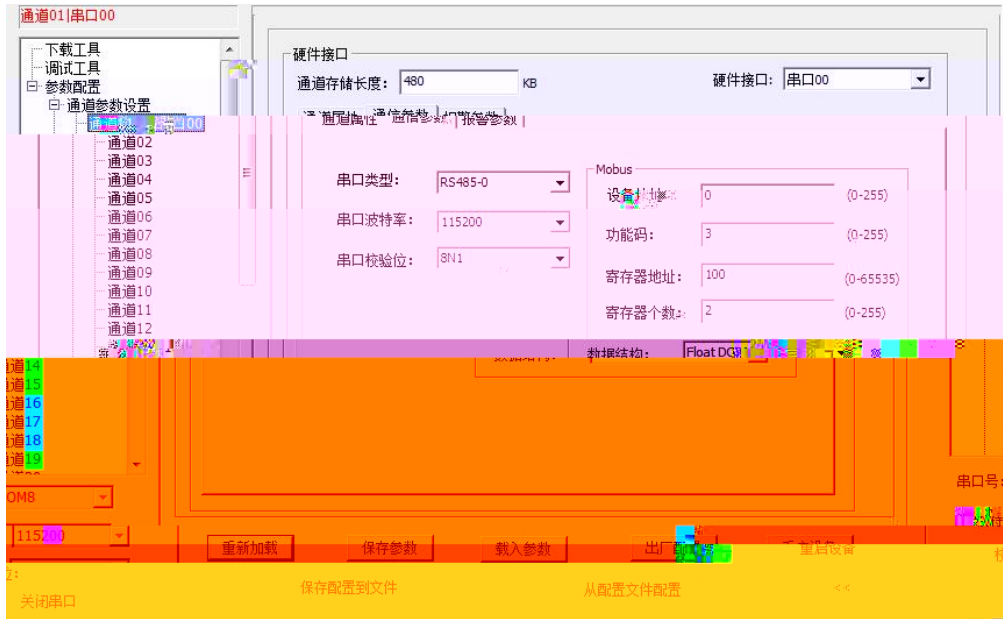

AcXvi g FH

AC86i G FH

AC86i G FH

	8C ?\$

)" &" (587

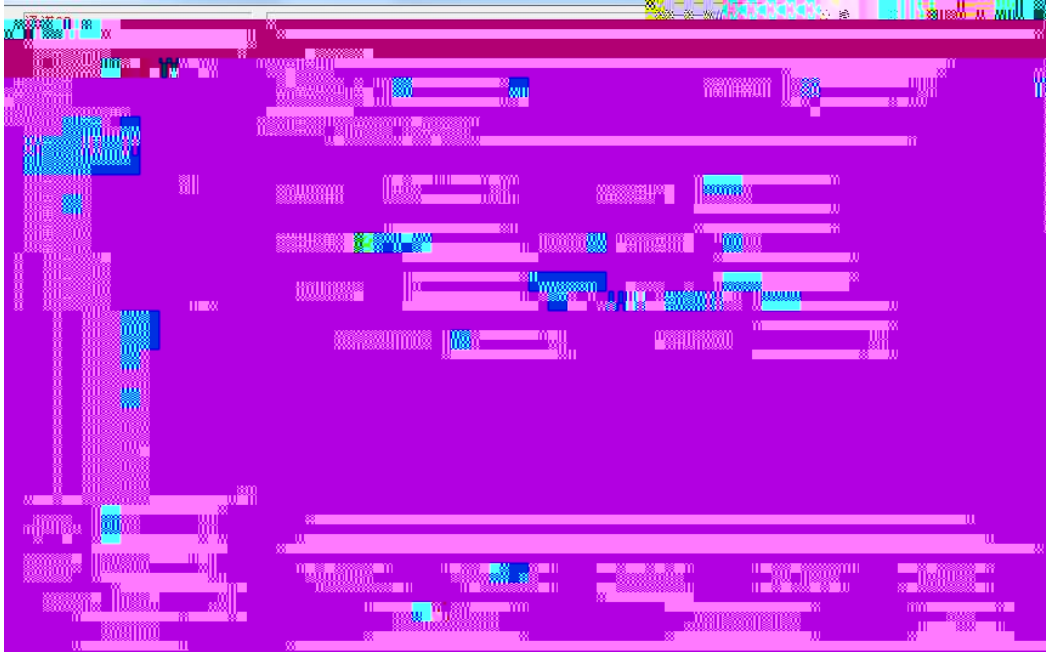

	HG) \$% \$! *)')g
	FH
	% \$\$
	VaPaP a' #g



587

#

	8C ?\$

)" &" 8=

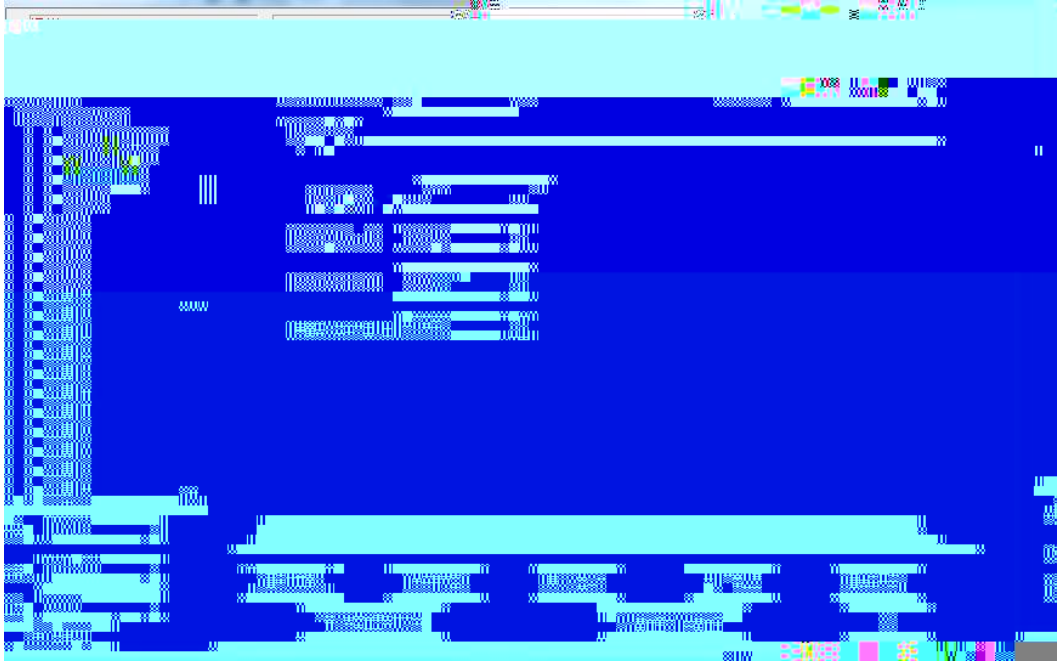

	# #
	8C ?\$

)" &" *



	# # #
	FH \$! &))g
	% \$\$
	% \$\$
	V#PaPa' #gP aa

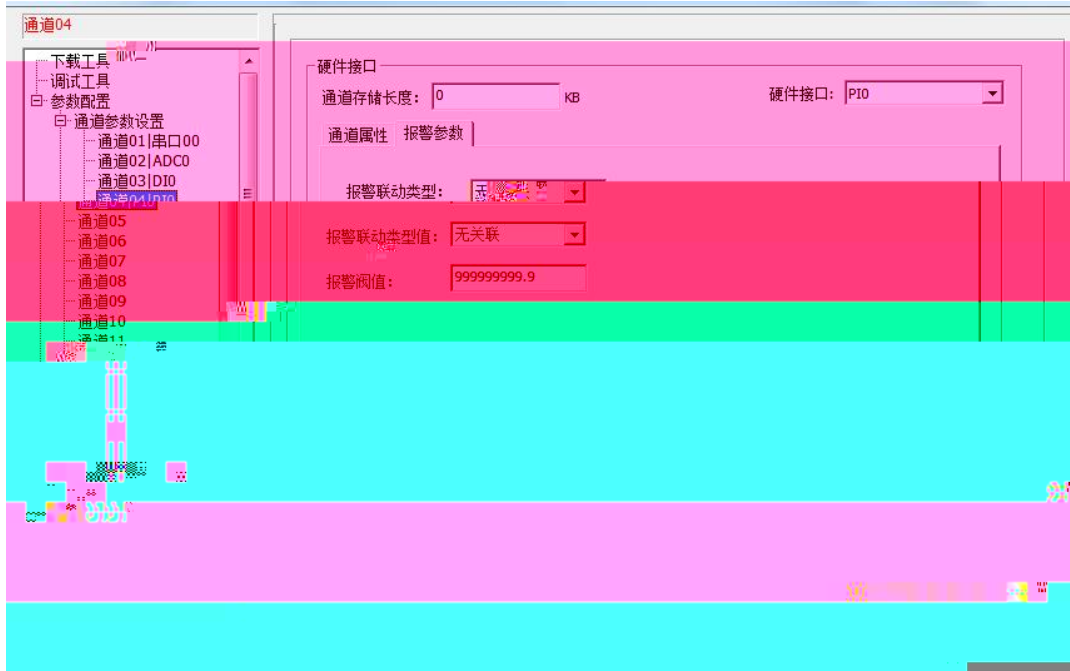

	8C ?\$

)"&"+

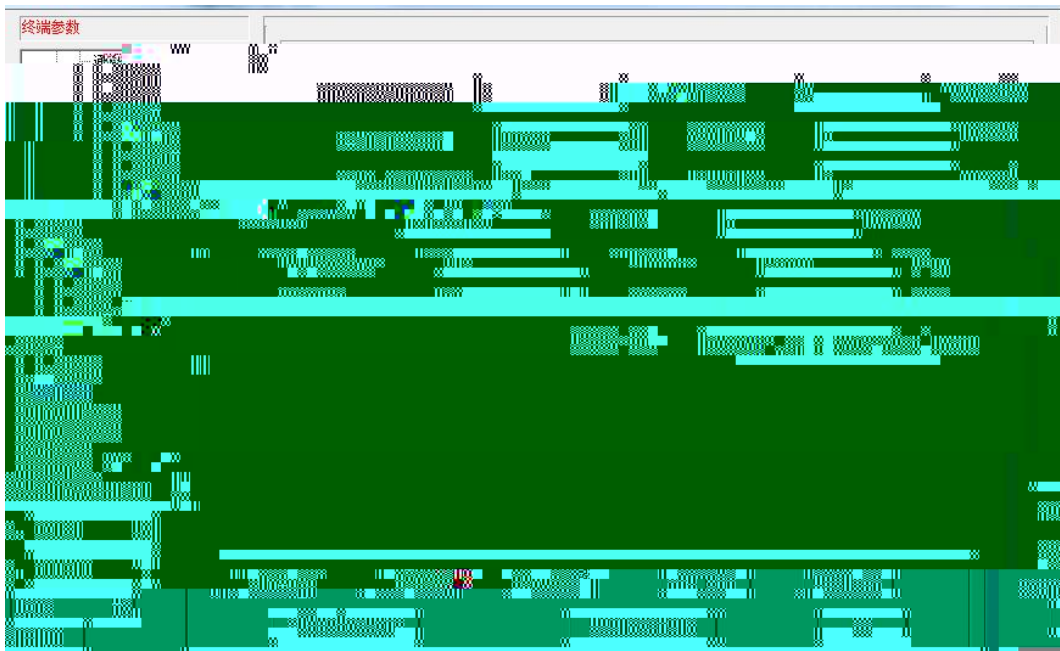

--	--

	\$		
	%	FG& ' & \$	
	&	FG& ' & \$	
	'	\$\$Vdgr %& & \$\$Vdg	FG& ' & \$
	,	B% , C% , 9%	FG& ' & \$
			%
		J	
	*	\$! *) ') g	
	%	\$!) - a] b	
	%	\$! & \	
	%	\$! ' \$ X	
	*	& % &	DK
	&	& % &	GH
	& (& % &	AB

)" & ,



	(
	GAG#H7D# # # DGHB# # # I 8D (" % - _____
	H7D#I 8D =D GAG
	H7D#I 8D
	H7D#I 8D 8BG =D

)" &" -

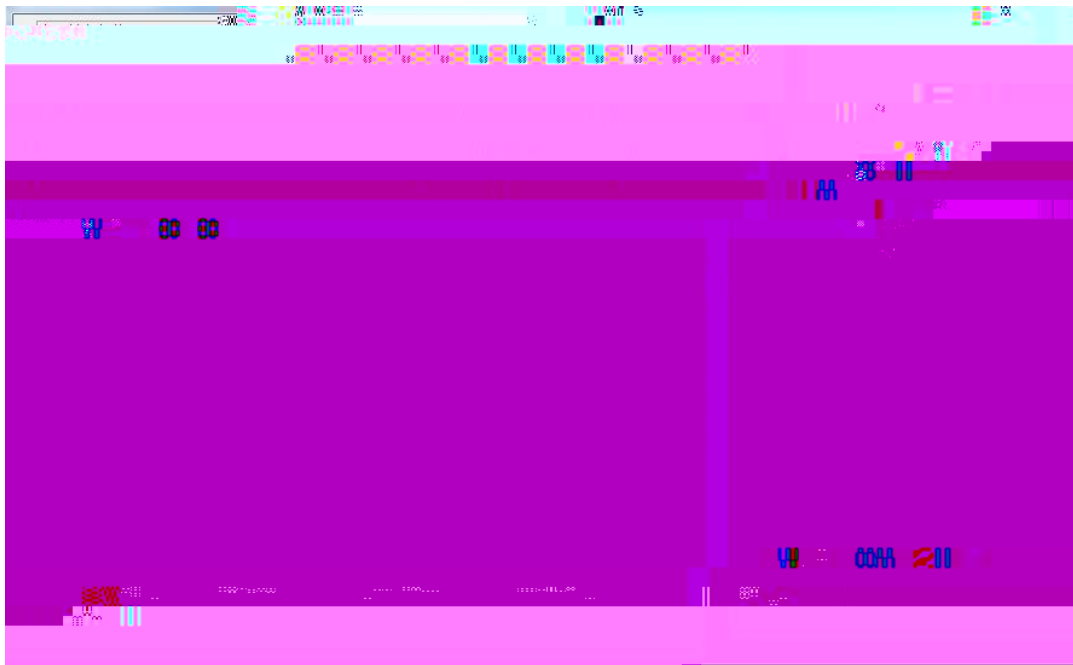

5DB	
5DB	
5DB	
5DB	
	H7D *\$ I 8D ' %
@7D	

)" &" %\$

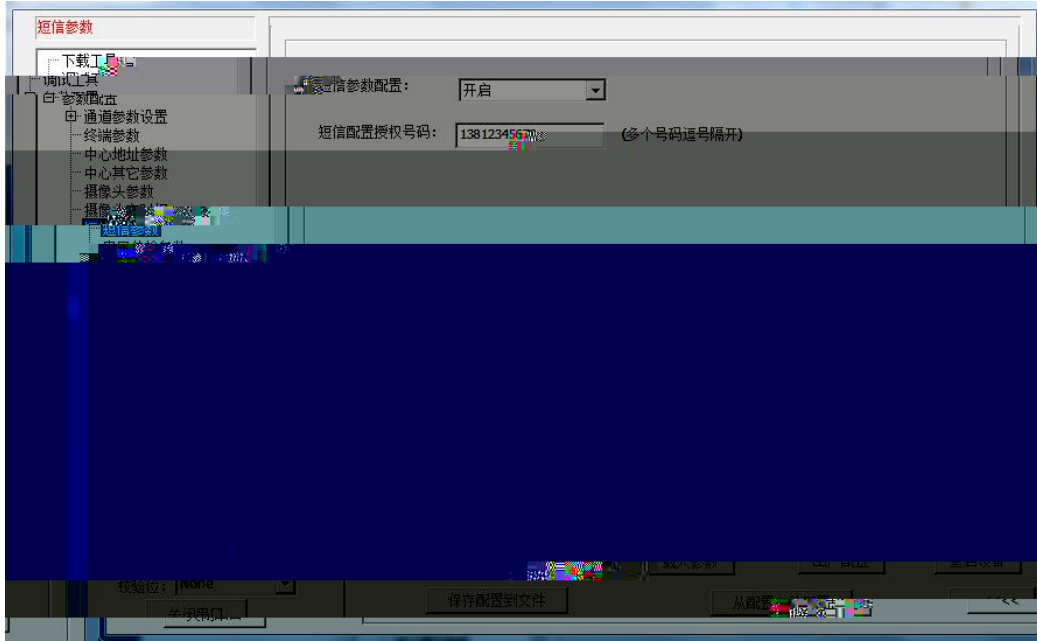

)" &" %&



	& & & & (,)
	' \$\$Vdgr %& & \$\$Vdgr
	, B% , C% , 9%

)" &" %&

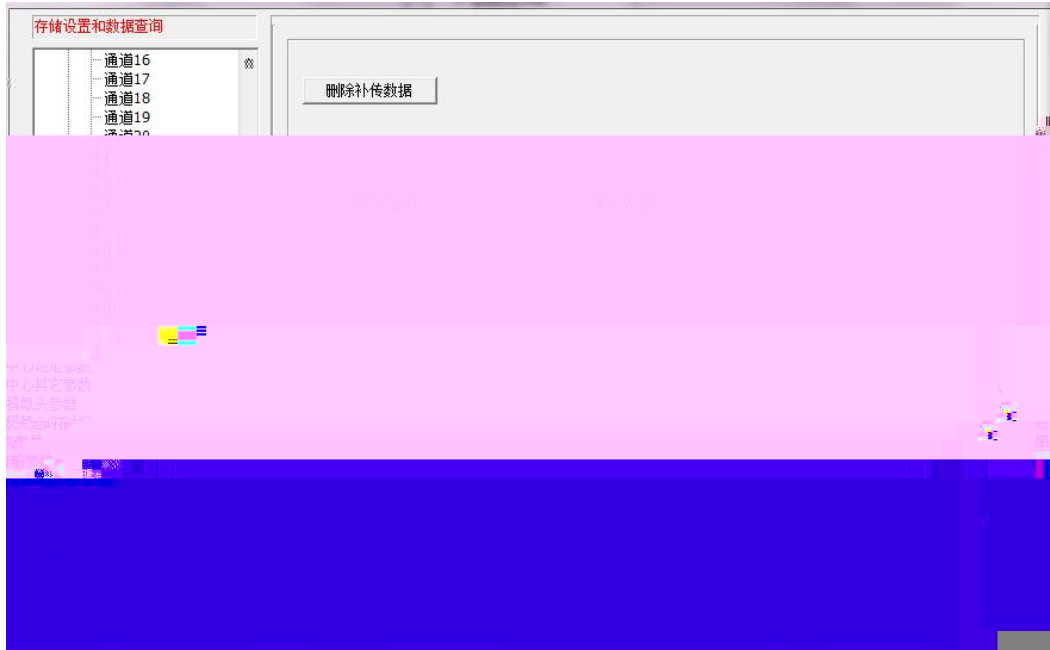

)''

%\$

5H

/

)'''%

0 / %/ &2

5H

5H

0%& (*) / AI @H-G9F\$%1%&\$" (& ("*- , / AI @H-DCFH\$%1) \$\$+2

%& (*) *z

%&\$" (& ("*- ,

) \$\$+

5H

5H

V&X

V&X

*" %

FG& ' &

FG& ' & (,)

FH

D7

FH

%

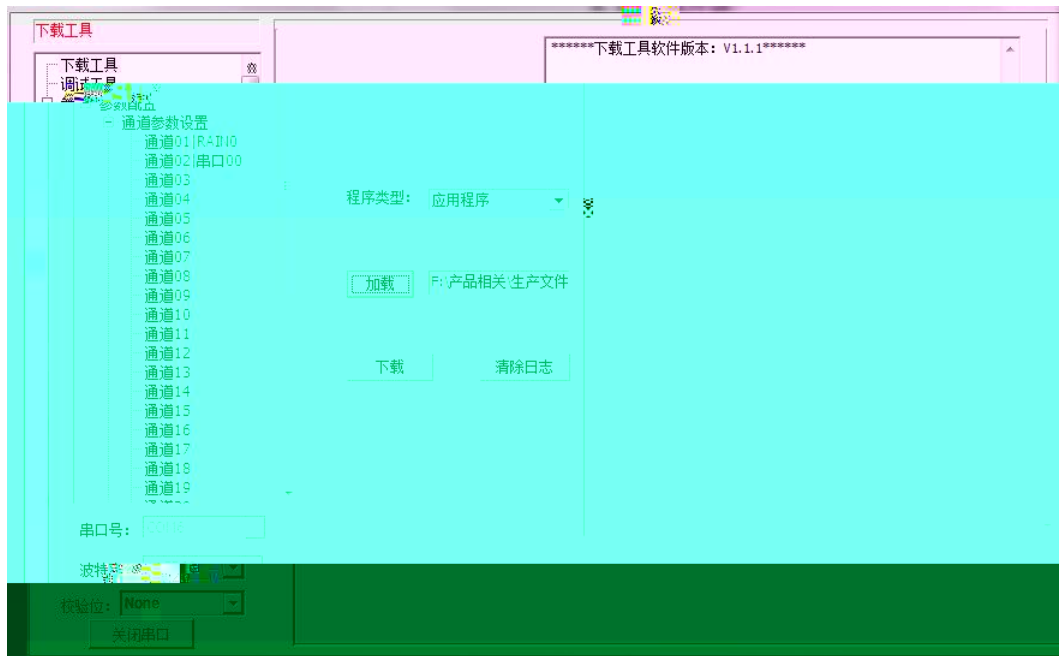

&"

6=B

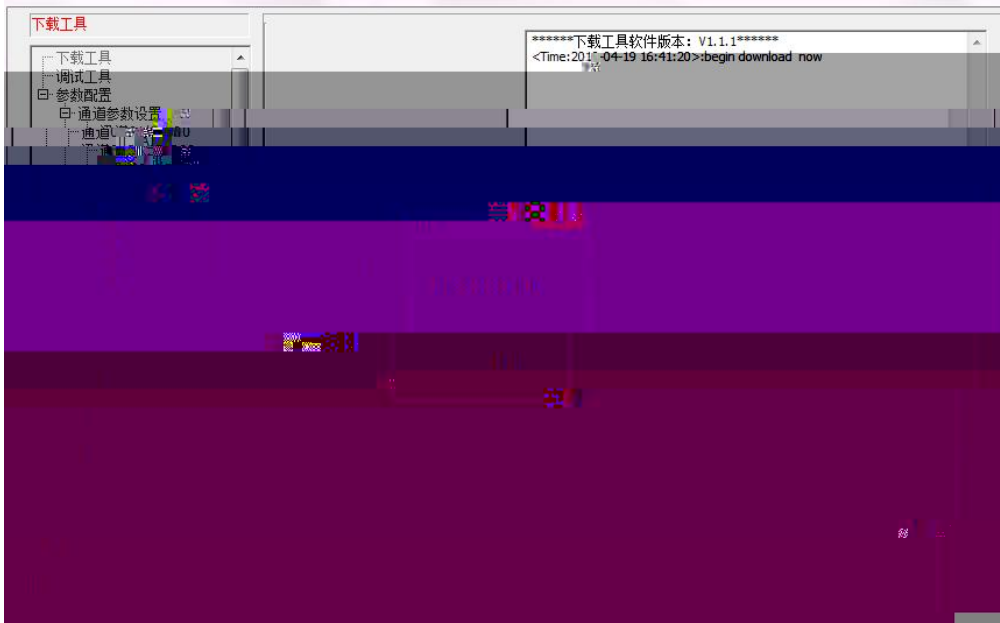

' " FH



(" FH

Xckb` cUX gi WWgg c_

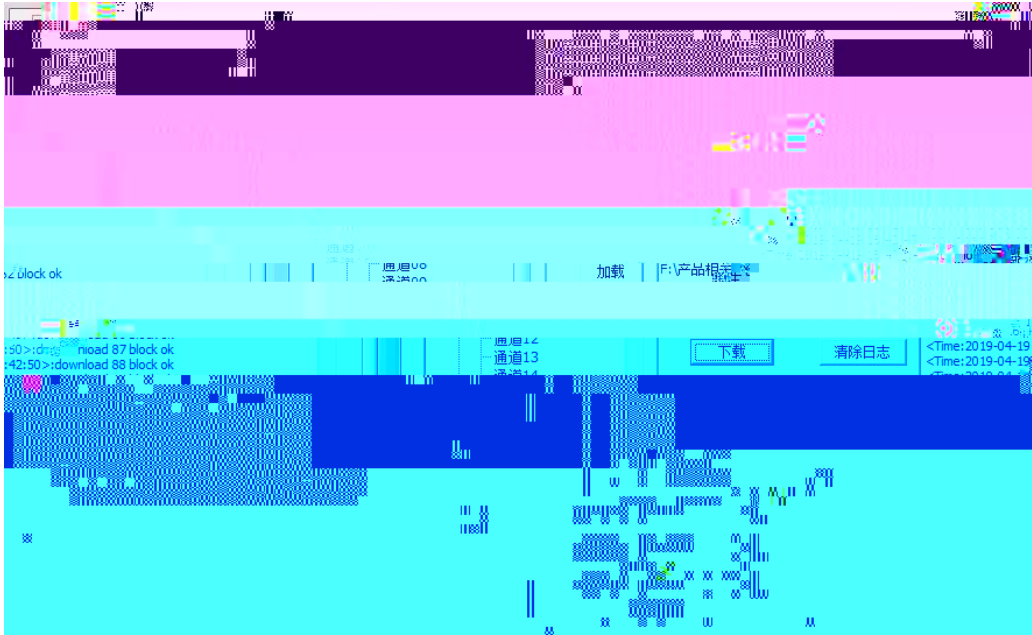

FH

5H

% FH7

	5H	
FH7	5HŽ9L77@1LL	5HŽ9L77@1&\$% #\$(#% ž%.)% \$\$ž)

&

	5H	
	5HŽ7<BGJ@9Bmm1l	?6 mm \$% ' \$ \$% ' \$ %\$&(\$?6 5HŽ7<BGJ@9B\$%l (, \$
	5HŽ7<BB@HMD9mm1l	mm \$% ' \$ \$% ' \$ l. \$ %\$% %\$, 8=\$! 8=+ &\$% &\$, 587\$! 587+ ' \$% ' \$& F5=B\$! F5=B% ' \$ ' ! ' \$(D=\$! D=% (\$% (% \$% % *\$% ; F5M 5HŽ7<BB@HMD9\$%l %\$%

&" %

	5H	
	5HŽ7CA=: CD9Bmm1l	mm \$% % \$% % l \$ % 5HŽ7CA=: CD9B\$%l %
	5HŽ7CA7C@H-A9mm1l	mm \$% % \$% % l \$! *)' ') \$ 5HŽ7CA7C@H-A9\$%l %\$

5HŽ7CAGD998\$%l - *\$\$

5HŽ7CAD5F=HMm1l l

mm \$% % \$% %
l .

5HŽ7CAD5F=HM\$%l, B%
AcXVi g

5HŽ7CAA6588Fm1l

mm \$% % \$% %
l . \$! &) ž

5HŽ7CAA6588F\$%l %
AcXVi g

5HŽ7CAA6: l B7m1l

mm \$% % \$% %
l . \$! &) ž

5HŽ7CAA6: l B7\$%l'
AcXVi g

5HŽ7CAA6F9; 588Fm1l

mm \$% % \$% %
l . \$! *)')

5HŽ7CAA6F9; 588F\$%l %\$\$
AcXVi g

5HŽ7CAA6F9; BI Am1l

mm \$% % \$% %
l . \$! &

5HŽ7CAA6F9; BI A\$%l %
AcXVi g

5HŽ7CAA685HMD9m1l

mm \$% % \$% %
l . _____

5HŽ7CAA685HMD9\$%l %
mm \$% % \$% %

5HŽ7CA@FAI DDm1l l

l l
5HŽ7CA@FAI DD\$%l %% &

5HŽ7CA@FA@Kmm1l l

	5H7CAF@BHM9mm1l	mm \$% % l. \$ %\$% %\$& 8C\$! 8C% &\$% &\$, ?\$! ?+ 5H7CAF@BHM9\$%l %\$%
	5H7CAF@BJ5@mm1l	mm \$% % l. !\$ & \$ 8C % 8C & 5H7CAF@BJ5@\$%l %

&" & 587

5H		
	5H587=: CD9Bmm1l	587 mm \$% \$(587\$ 587' l \$ % 5H587=: CD9B\$%l %
	5H5877C@H=A9mm1l	587 mm \$% \$(587\$ 587' l \$! *)'') \$ 5H5877C@H=A9\$%l %\$
	5H587DKF8@Mmm1l	FH mm \$% \$(587\$ 587' l \$! &) \$ 5H587DKF8@M\$%l &\$
	5H587577l mm1l l	mm \$% \$(587\$ 587' ll 5H587577l \$%l % \$\$
	5H5879@9Amm1l l	% mm \$% \$(587\$ 587' ll 5H5879@9A\$%l U&(\$, +

	5HŽ58765G9J5@mm111	mm \$% \$(587\$ 587' 11 5HŽ58765G9J5@\$%! % &
	5HŽ5877CFFJ5@mm111	mm \$% \$(587\$ 587' 11 5HŽ5877CFFJ5@\$%! % &
	5HŽ587I B=Hm111	* mm \$% \$(587\$ 587' 11 5HŽ587I B=H\$a' #g
587	5HŽ587HMD9mm11	587 mm \$% \$(587\$ 587' l \$! % \$ % 5HŽ587HMD9\$%\$
	5HŽ587I DDFB; mm111	fl t mm \$% \$(587\$ 587' 11 5HŽ587I DDFB; \$%\$&\$
	5HŽ587@CKFB; mm111	fl t mm \$% \$(587\$ 587' 11 5HŽ587@CKFB; \$%\$&\$
	5HŽ587I DDJ5@mm111	mm \$% \$(587\$ 587' 11. (! &\$a5 \$!) 5HŽ587I DDJ5@\$%\$&\$
	5HŽ587@CKJ5@mm111	mm \$% \$(587\$ 587' 11. (! &\$a5 \$!) 5HŽ587@CKJ5@\$%\$ (
	5HŽ587@FAI DDmm111	587 mm \$% \$(587\$ 587' 11

5HŽ587@FAI DD\$%!%% &

587

nm \$% \$(587\$ 587'

5HŽ587@FA@CKmm11

11

5HŽ587@FA@CK\$%!%% &

587

5HŽ587@FAJ5@m11

		? \$! ?+
		5HŽ==CF@HBM %! %\$\$%
	5HŽ==CF@HJ5@mm11	mm \$% \$(8=\$ 8=' l . \$! & \$ 8C % 8C & 5HŽ==CF@HJ5@\$%1%

&" (

	5H	
--	----	--

5HŽ7BHF=: CD9Bmm11

mm \$% \$& \$% \$& D=\$! D=%
l \$ %

5HŽ7BHF=: CD9B\$%1%

5HŽ7BHFC Dmm11

mm \$% \$& \$% \$& D=\$! D=%
l \$
%
&
,

5HŽ7BHFC D\$%1&

5HŽ7BHFI B=Hm11 l

mm \$% \$& \$% \$& D=\$! D=%
l l 5

5HŽ7BHFI B=H\$%1a' #g

5HŽ7BHFG<5?9AGmm11

mm \$% \$& \$% \$& D=\$! D=%
Bl \$! *)')') \$

5HŽ7BHFG<5?9AG\$%1) \$

ë

5HŽ7BH577l mm11 l

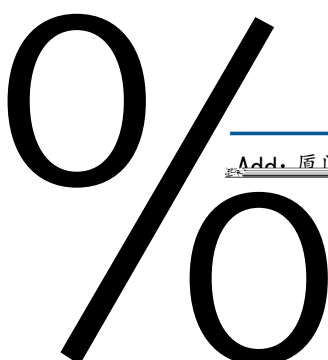



5H7BHF5771 \$%!% \$\$

		5HŽ896l ; 1&
	5HŽ86; 7CAGD9981l	FG& & \$ 5HŽ86; 7CAGD9981%& & \$\$
	5HŽ86; 7CAD5F=HMI l	FG& & \$ l l , B% , 9% , C% 5HŽ86; 7CAD5F=HM, 9%
	5HŽG=ABC1l l	l l % 5HŽG=ABC1% , %& () * +,
	5HŽDKF@CKJC@H1l l	l l 5HŽDKF@CKJC@H1%&)
	5HŽl DBHFA=B1l	l \$! *)')') \$ 5HŽl DBHFA=B1)
	5HŽA=B=BH9FJ5@l	l \$!) - \$ 5HŽ A=B=BH9FJ5@l\$
	5HŽ<Cl F=BH9FJ5@l	l \$! & \$ 5HŽ <Cl F=BH9FJ5@l\$
	5HŽ85H9=BH9FJ5@l	l \$!' \$ \$ 5HŽ 85H9=BH9FJ5@l,
	5HŽ<6DK1l	&%& DK * l 5HŽ<6DK1%& () *
	5HŽ<6GH1l	&%& GH & l 5HŽ<6DK1&+
	5HŽ<6AB1l	&%& AB &(l . 5HŽ<6AB1 \$%\$\$\$5, - \$\$%\$: \$\$%\$ - 87\$
	5HŽ=: l D6M@CG91l	l \$ % 5HŽ=: l D6M@CG91\$

(

5H		
	5HŽG9FBI A1I	I \$! (\$ 5HŽG9FBI A1%
	5HŽHF5BAC89nm1I	mm \$% \$(% (\$)! \$, % (I \$ % H7D & , (DGH) * + I 8D 5HŽHF5BAC89\$%I %
	5HŽAI @H-G9Fnm1I I	H7D#I 8D =D mm \$% \$(% (\$)! \$, % (I I 5HŽAI @H-G9F\$%I] gcXYj " d] Wd" bYh
	5HŽAI @H-DCFHnm1I I	mm \$% \$(% (\$)! \$, % (I \$! *)')' 5HŽAI @H-DCFH\$%I %\$%&%
	5HŽAI @H-8BG\$%I I I	I I 5HŽAI @H-8BG\$%I, ", ", "
	5HŽAI @H-8BG\$&1I I	I I 5HŽAI @H-8BG\$&1, ", ", "

		' FG(,)! \$ (FG(,)! % 5HŽHF5B7CAHMD91 &
	5HŽHF5B7CAGD9981I	I 5HŽHF5B7CAGD9981%& &\$ \$
	5HŽHF5B7CAD5F=HM1	I. , B%ž, 9%ž, C% 5HŽHF5B7CAD5F=HM\$%ž, B%

\$	I bg] [bYX %*V] h 56	% &	\$% '\$ \$& %& && \$8 ' (% &&?% %\$, +&%
%	I bg] [bYX %*V] h 65	% &	\$% '\$ \$& %& && \$8 ' (% %&& %\$ (' , *
&	G] [bYX %*V] h 56	% &	\$% '\$ \$& %& && \$8 ' (% &&?% %\$, +&%
'	G] [bYX %*V] h 65	% &	\$% '\$ \$& %& && \$8 ' (% %&& %\$ (' , *
(I bg] [bYX ' &V] h 5678	' & (\$% '\$ \$& %& && ' ' ((7* 7' % ((' &&?% %\$ %&((&\$%+()
)	I bg] [bYX ' &V] h 6587	' & (\$% '\$ \$& %& && ' ' ((7* 7' % ' ' ((%&& %\$, *\$ \$- , ,) \$
*	I bg] [bYX ' &V] h 7856	' & (\$% '\$ \$& %& && ' ' ((7* 7' % &&?%& ((' %\$) +&) * - %&
+	I bg] [bYX ' &V] h 8765	' & (\$% '\$ \$& %& && ' ' ((7* 7' % %&& ' ((%\$ & + () (\$&\$
,	G] [bYX ' &V] h 5678	' & (\$% '\$ \$& %& && ' ' ((7* 7' % ((' &&?% %\$ %&((&\$%+()

-	G][bYX '&V]h 6587	' & (\$% '\$ \$& %& && '' ((7* 7' %* '' ((%&&& %\$, *\$\$. ,) \$
%\$	G][bYX '&V]h 7856	' & (\$% '\$ \$& %& && '' ((7* 7' %* &&%&('' %\$)+%) *-%&
%%	G][bYX '&V]h 8765	' & (\$% '\$ \$& %& && '' ((7* 7' %* %&&' ((%\$ & +)(\$&&\$
%&	: `cUh 5678	' & (\$% '\$ \$& %& && '' ((7* 7' %* ((' &&%& +%")' && ,
%	: `cUh 6587	' & (\$% '\$ \$& %& && '' ((7* 7' %* '' ((%&&& \$" \$\$\$\$\$\$
%&	: `cUh 7856	' & (\$% '\$ \$& %& && '' ((7* 7' %* &&%&('' \$" \$\$\$\$\$\$
%)	: `cUh 8765	' & (\$% '\$ \$& %& && '' ((7* 7' %* %&&' ((\$" \$\$\$\$\$\$

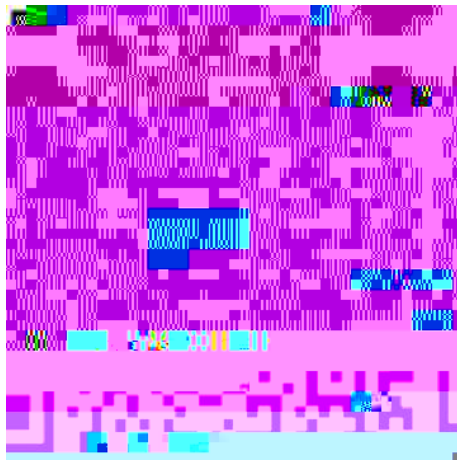

kkk" hcd! | ch" Wca
gYfj | W4hcd! | ch" Wca